

## Simulation of spatial variation of plankton communities in the South Central Vietnam sea by ROMS model

**Vu Thi Vui**

*Faculty of Hydro-Meteorology and Oceanography, VNU University of Science, Hanoi, Vietnam*  
E-mail: [vuivt89@gmail.com](mailto:vuivt89@gmail.com)

Received: 5 March 2018; Accepted: 21 November 2018

©2019 Vietnam Academy of Science and Technology (VAST)

### **Abstract**

This study preliminarily applies the Regional Ocean Modeling System (ROMS) in the two major monsoon seasons (Northeast and Southwest monsoons) for the South Central Vietnam sea (9–14.5°N, 105–112°E), in which the hydrodynamic and ecological modules are coupled. The results show that the plankton only develop in 200 m water on the top, concentrated mainly in the 0–70 m layer and in maximum biomass of 15–40 m layer. In the Northeast monsoon season, the plankton are concentrated mainly in the northern part and open seas of the area, while in the Southwest monsoon season, they are concentrated in the upwelling and adjacent southern areas. These results correctly reflect the basic law of the development of plankton communities in the sea area.

**Keywords:** ROMS, hydrodynamic, ecological, South Central Vietnam sea.

## INTRODUCTION

ROMS (Regional Ocean Modeling System) is a research product of the University of California, Rutgers University (United States) and IRD organization (France), with many applications in researches of marine hydrodynamics, ecology and environment. This is a modern model, using primitive equations. There are many options for convection diagrams, pressure gradients, turbulent closures, boundary conditions for a variety of purposes. ROMS is currently open source so it is a high community model, developed by many researchers, applied to many scales of space from coast to ocean and on time scales from seasonal to interdecadal [1, 2].

There have been only a few studies applying ROMS on the hydrodynamic models [3], but there have been no studies related to the marine eco-environment models in Vietnam. For the purpose of approaching and initially testing the method, this paper presents the latest research results of applying the coupled physical - biogeochemical model of ROMS in the South Central Coast of Vietnam sea area in which the ecological characteristics are brought about by summer raising water activities.

## RESEARCH METHODS

### Introducing ROMS model system combining marine hydrodynamics and ecology

ROMS has been researched and developed at the University of California, Rutgers University (USA) and IRD (France) for the purposes of calculating circulation, ecosystems and biochemical-biochemical cycles, transporting sediments in different coastal areas. This study uses the ROMS version of the IRD organization - ROMS\_AGRIF, supported by the ROMSTOOLS toolkit to process input/output information for pre- and post-processes of the model runnings [2].

ROMS model uses open surface, three-dimensional, terrain-following coordinate system. The hydrodynamics of ROMS solves Reynolds' average Navier - Stokes equation system, using Boussinesq approximation and hydrostatic approximation. The equations in ROMS are written in Descartes coordinates (horizontal) and Sigma coordinates (vertical).

The system of equations of motion, continuity, state and diffusion of the model is as follows:

$$\frac{\partial(H_z u)}{\partial t} + \frac{\partial(u H_z u)}{\partial x} + \frac{\partial(v H_z u)}{\partial y} + \frac{\partial(\Omega H_z u)}{\partial \sigma} - f H_z v = -\frac{H_z}{\rho_0} \frac{\partial p}{\partial x} - H_z g \frac{\partial \zeta}{\partial x} - \frac{\partial}{\partial \sigma} (\overline{u'w'}) - \frac{\nu}{H_z} \frac{\partial u}{\partial \sigma} \quad (1)$$

$$\frac{\partial(H_z v)}{\partial t} + \frac{\partial(u H_z v)}{\partial x} + \frac{\partial(v H_z v)}{\partial y} + \frac{\partial(\Omega H_z v)}{\partial \sigma} + f H_z u = -\frac{H_z}{\rho_0} \frac{\partial p}{\partial y} - H_z g \frac{\partial \zeta}{\partial y} - \frac{\partial}{\partial \sigma} (\overline{v'w'}) - \frac{\nu}{H_z} \frac{\partial v}{\partial \sigma} \quad (2)$$

$$0 = -\frac{1}{\rho_0} \frac{\partial p}{\partial \sigma} - \frac{g}{\rho_0} H_z \rho \quad (3)$$

$$\frac{\partial \zeta}{\partial t} + \frac{\partial(H_z u)}{\partial x} + \frac{\partial(H_z v)}{\partial y} + \frac{\partial(H_z \Omega)}{\partial \sigma} = 0 \quad (4)$$

$$\rho = f(T, S, p) \quad (5)$$

$$\frac{\partial(H_z C)}{\partial t} + \frac{\partial(u H_z C)}{\partial x} + \frac{\partial(v H_z C)}{\partial y} + \frac{\partial(\Omega H_z C)}{\partial \sigma} = -\frac{\partial}{\partial \sigma} (\overline{C'w'}) - \frac{\nu}{H_z} \frac{\partial C}{\partial \sigma} + C_{source} \quad (6)$$

Here:  $u$ ,  $v$ ,  $\Omega$  are corresponding velocity components in the  $x$ ,  $y$ ,  $\sigma$  directions;  $\zeta$  and  $h$  - wave-averaged free-surface elevation and depth of seabed below mean sea level;  $H_z$  - vertical

stretching factor;  $f$  - coriolis parameter;  $g$  - gravitational acceleration;  $\nu$  - viscosity coefficient (in 1-2) and diffusion (in 6) (this study uses a viscosity coefficient of 0 and a

diffusion coefficient of 30);  $\rho$  and  $\rho_0$  - density and standard density;  $T$ ,  $S$  and  $p$  - temperature, salinity and pressure;  $C$  and  $C_{source}$  - tracer quantity (temperature, salt,...) and tracer source/sink terms; dash above - indicates the average time; prime (') - turbulent fluctuations. Turbulent closure is achieved by parameterization of Reynolds stress and turbulent flux with the presence of eddy viscosity for momentum ( $K_M$ ) and eddy diffusivity for tracers ( $K_H$ ).

$$\overline{u'w'} = -K_M \frac{\partial u}{\partial z} \quad (7)$$

$$\overline{v'w'} = -K_M \frac{\partial v}{\partial z} \quad (8)$$

$$\overline{C'w'} = -K_H \frac{\partial C}{\partial z} \quad (9)$$

The importance and complexity of the problem are to explicitly identify the  $C_{source}$  source functions, because the existence of any component other than depending on environmental conditions depends on their interaction with many other components through biochemical-physiological processes.

Currently, the ecological models in ROMS have 4 types. Type 1 is a model of NPZD with 4 state variables including 1 nutritional N (Nutrient), 1 floating P (Phytoplankton), 1 floating Z (Zooplankton) and 1 D (Detritus). The complexity increases in type 2 with more than 1 nutritional variable, type 3 has two floating plants and type 4 has multi species [1]. Initially for the purpose of approaching and testing the method, this study uses a simple model NPZD [4], in which the nutritional variable is selected as inorganic nitrogen component, namely nitrate ( $NO_3^-$ ). In this model, the nitrogen element is metabolized by four N-P-Z-D components by 8 biochemical-physiological processes (fig. 1), in which: 1 - photosynthesis of P; 2 and 3 - nutrition and respiration of Z (with  $\beta$  is anabolic rate); 4 and

5 - death of P and Z; 6 - D mineralization; 7 and 8 - deposition of P and D.

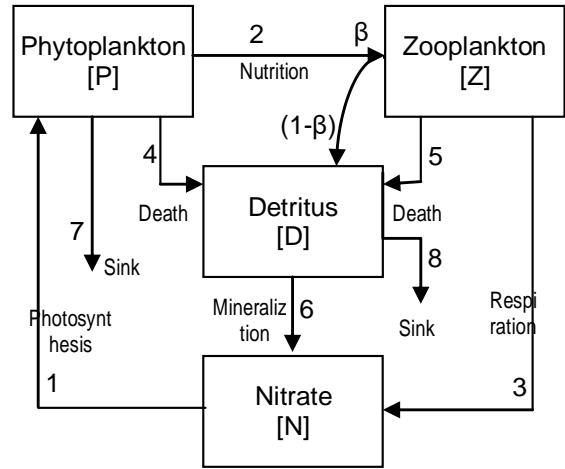

Fig. 1. Diagram of nitrogen cycle (NPZD model [4])

For each component, the  $C_{source}$  function (present in equation 6 above) is calculated by summing up the amount of increase/decrease in concentration or biomass in the metabolic processes:

$$C_{source}^P = m_1[P] - m_2[Z] - m_4[P] - m_7[P]$$

$$C_{source}^Z = m_2[Z] - (1 - \beta)m_2[Z] - m_3[Z] - m_5[Z]$$

$$C_{source}^D = (1 - \beta)m_2[Z] + m_4[P] + m_5[Z] - m_6[D] - m_8[D]$$

$$C_{source}^N = -m_1[P] + m_3[Z] + m_6[D]$$

Where:  $m_1, \dots, m_8$  is the specific rate of change of a concentration or biomass unit in each corresponding transformation process (e.g.  $m_1$  is the specific rate of increasing the biomass of phytoplankton by photosynthesis, also is the specific rate of nitrate concentration decline). Specific speeds have a unit of 1/day, their values can be pre-selected or calculated according to local ecological-environmental conditions such as temperature, light, transparency, nutrient salt concentration... [1, 5-7]. In this model:

$$m_1 = N / K_N + N \quad ab^T \alpha Q / \sqrt{ab^T^2 + \alpha Q^2}; \quad m_2 = m_{2max} P / K_P + P$$

In which:

$$Q = Q_0 \cdot \exp(-K_W + K_C \cdot R_{Ch/N} \cdot R_{C/N} \cdot P \cdot Z)$$

Is photosynthetic radiation ( $W/m^2 \cdot day$ ) at depth  $Z$  and  $Q_0$  is its value on the sea surface. Other symbols and many related ecological parameters are explained in table 1.

Table 1. Ecological coefficients and selected values for the study area [8]

No.	Variable	Description	Value	Unit
1	$K_W$	Light attenuation due to sea water	0.04	1/m
2	$K_C$	Light attenuation by chlorophyll-a (chla)	0.024	$m^2/mgchla$
3	$R_{C/N}$	C:N ratio for phytoplankton	6.625	-
4	$R_{Ch/C}$	Chla:C (chlorophyll-a and carbon) ratio for phytoplankton	0.02	-
5	$\alpha$	Coefficient determining the effect of light on photosynthesis	1.0	$m^2/W$
6	$a$	Maximum growth rate of phytoplankton at 0°C	0.8356	1/day
7	$b$	Temperature coefficient for maximum growth of phytoplankton	1.066	-
8	$K_N$	Half-saturation constant for phytoplankton	0.5	$mmolN/m^3$
9	$K_P$	Zooplankton half-saturation constant for ingestion of phytoplankton	1.0	$mmolN/m^3$
10	$m_{2max}$	Maximum zooplankton growth rate	0.9	1/day
11	$\beta$	Zooplankton assimilation efficiency of phytoplankton	0.75	-
12	$m_3$	Zooplankton specific excretion rate	0.1	1/day
13	$m_4$	Phytoplankton mortality to detritus rate	0.04	1/day
14	$m_5$	Zooplankton mortality to detritus	0.1	1/day
15	$m_6$	Detrital remineralization to $NO_3$ rate	0.05	1/day
16	$m_7$	Sinking velocities for phytoplankton	0.5	1/day
17	$m_8$	Sinking velocities for detritus	5.0	1/day

It can be seen that although this NPZD biogeochemical model is relatively complicated, there are still many processes that are worth considering such as plant respiration, animal sinking, mineralization and protein metabolism to turn the substance into ammonium-nitrite-nitrate,... [5], or only parameterize  $m_1, m_2$ . In addition, due to the unprecedented ecological coefficients published from previous studies to include in the computational model, this study applies the experience gained from studies on the South Central Vietnam marine ecological model combined with the reference to the limits of ecological coefficients from the study of Fasham et al., (1990). These defects need to be studied and supplemented.

**Data source**

In the model application in the South Central Vietnam sea, horizontal grid with a resolution of 1/4 degrees in both latitude and longitude is used. The vertical is divided in 10 sigma levels. Although the marine area concerned for extracting results has a limit of 9–14.5°N, 107–

112°E, the domain has been extended to 7–19°N and 105–118°E to reduce the effect of the boundary. The model averages 12 months, runs for 2 years, with the stability of the model when comparing December data of 2 years to reach a high correlation coefficient (above 0.99). Calculations are shown for January and July representing 2 wind seasons.

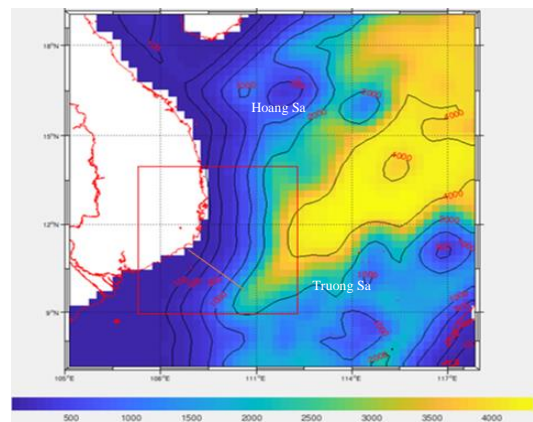

Fig. 2. Domain topography and the concerned section

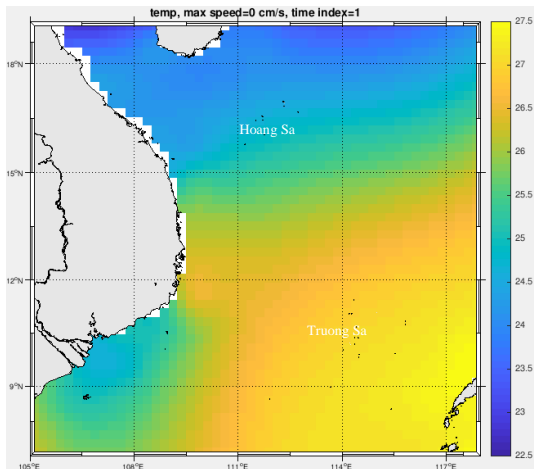

Fig. 3. Temperature initial condition

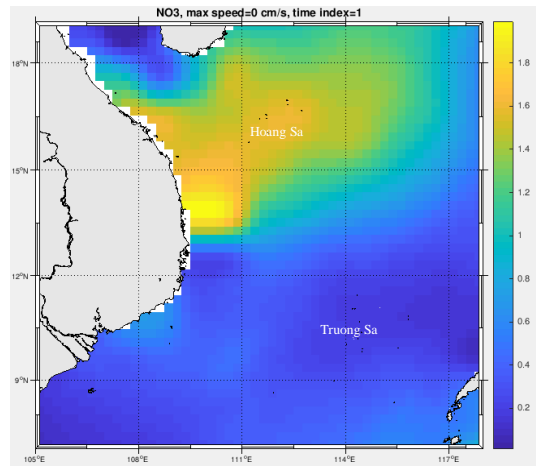

Fig. 6. NO<sub>3</sub> concentration initial condition

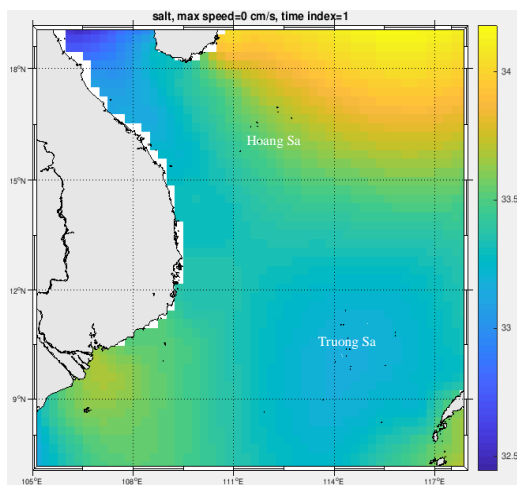

Fig. 4. Salinity initial condition

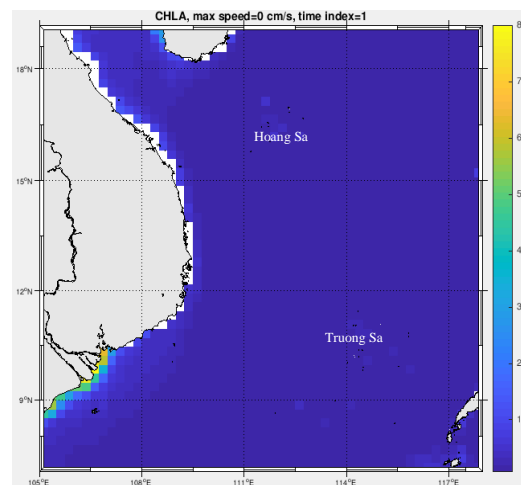

Fig. 7. Chlorophyll-a concentration initial condition

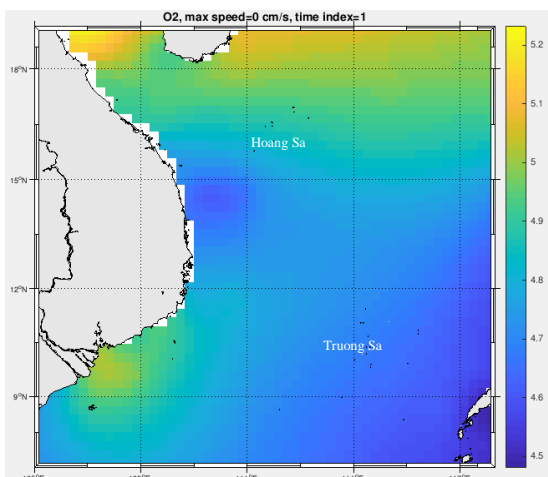

Fig. 5. O<sub>2</sub> concentration initial condition

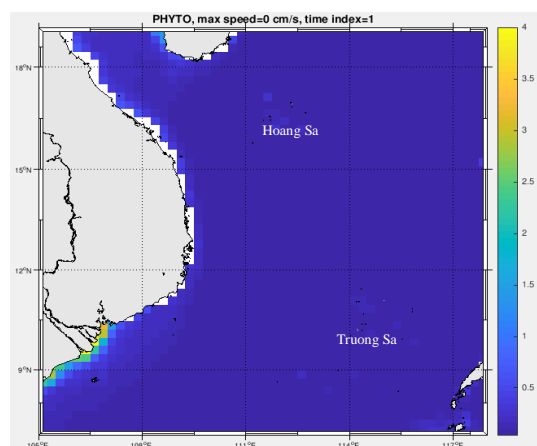

Fig. 8. Phytoplankton biomass initial condition

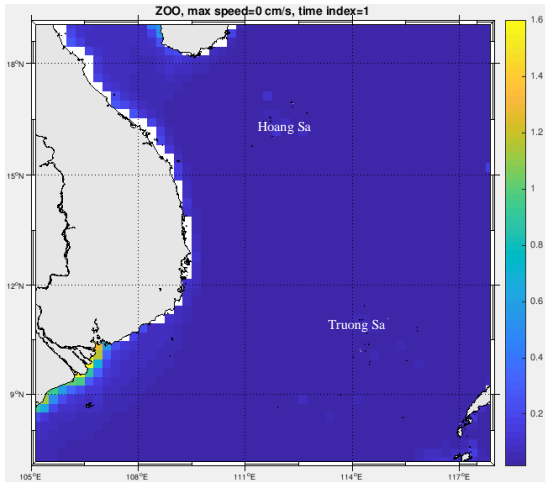

Fig. 9. Zooplankton biomass initial condition

The domain topography is calculated from ETOTO2 source with a resolution of 2 minutes; meteorological factors that create input of impact force are taken from COADS05 source (monthly average data of meteorological parameters of sea surface); oceanographic data

that create boundary and initial conditions are taken from the WOA2009 source (monthly average global data of marine hydrological factors) [9]; river source data is included as the 12-month average water flow of the Mekong from the global river data Dai and Trenberth. The chlorophyll data is taken from the SeaWiFS satellite data set. Initial conditions give zero for water level and flow velocity. The boundary conditions used for land boundary are free sliding conditions, water boundary conditions are opened for all directions: east, west, south, and north of the calculation domain. The sources of data included are taken from monthly data sources with tens of years [9]. Ecological coefficients in the study area (Table 1) were selected based on the reference of existing studies in Vietnam and the world [1, 5, 6, 7]. Comparing the average chlorophyll concentration in September between research results and Peng Xiu's results [10] (Figure 20) showed relatively good results.

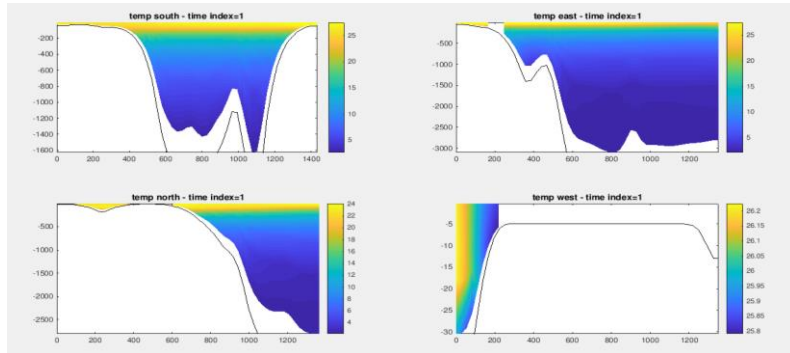

Fig. 10. Temperature boundary conditions

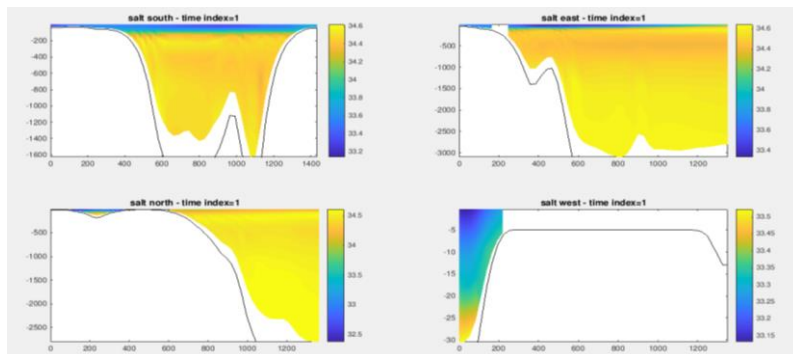

Fig. 11. Salinity boundary conditions

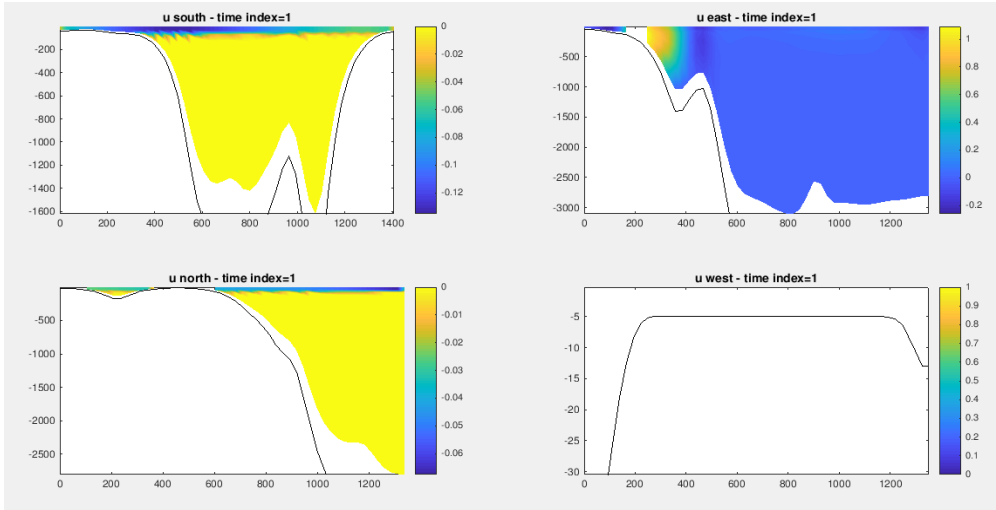

Fig. 12. Boundary conditions of velocity (Ox direction)

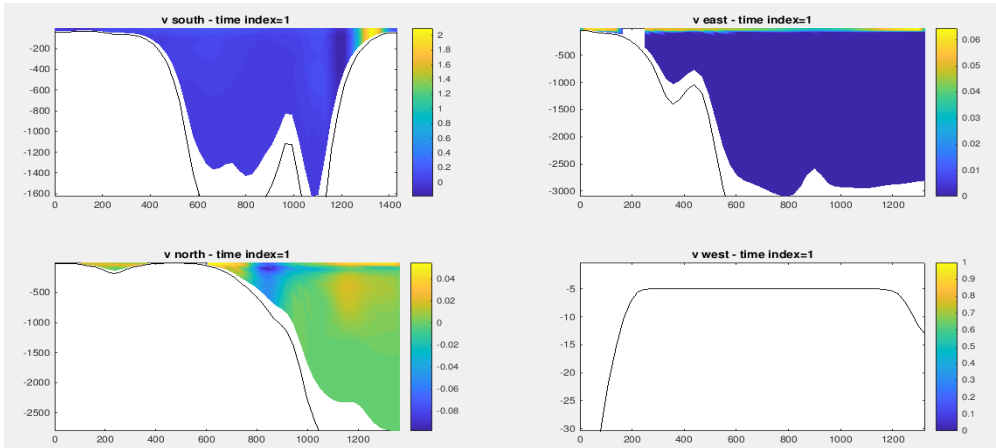

Fig. 13. Boundary conditions of velocity (Oy direction)

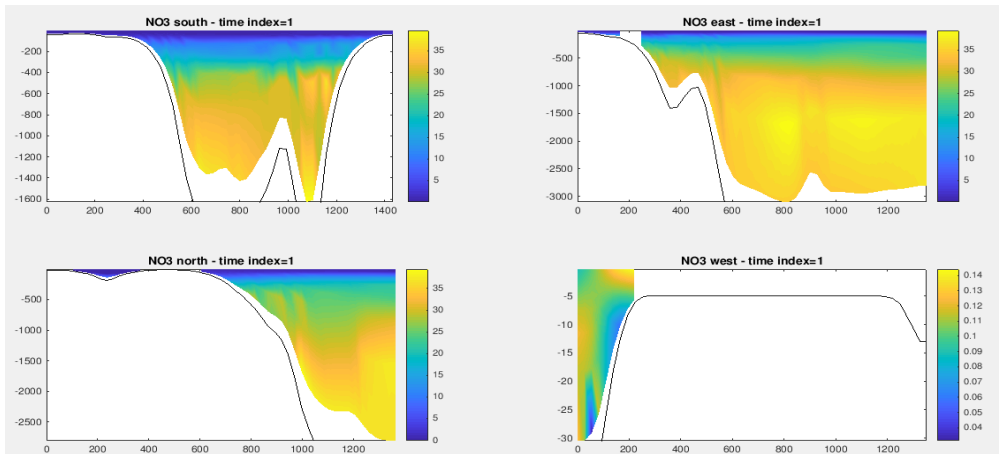

Fig. 14. NO<sub>3</sub> concentration boundary conditions

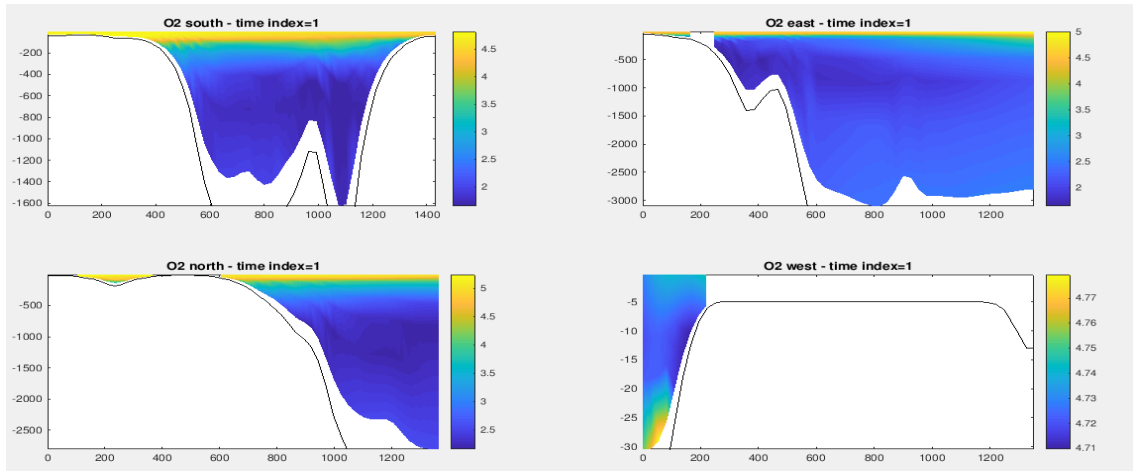

Fig. 15. O<sub>2</sub> concentration boundary conditions

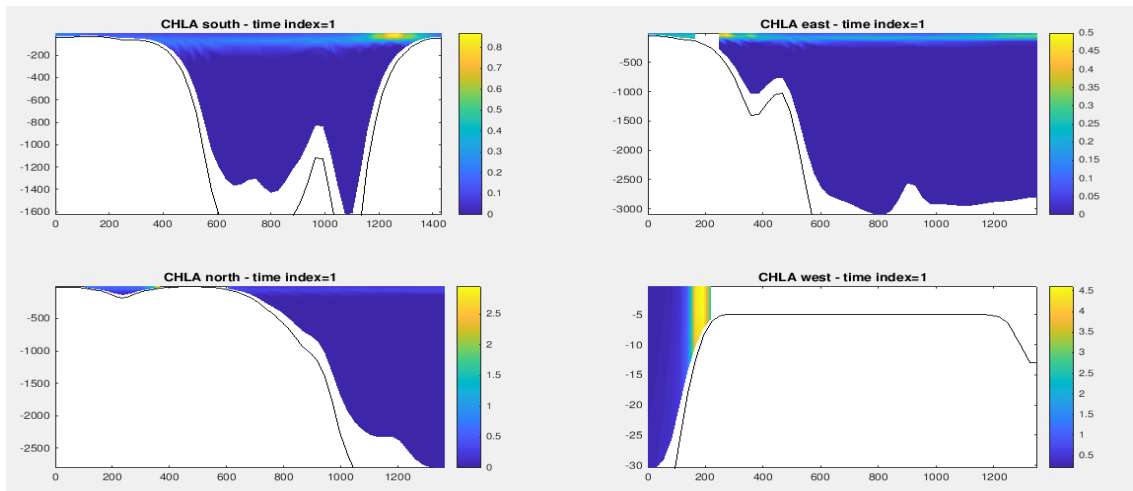

Fig. 16. Chlorophyll-a concentration boundary conditions

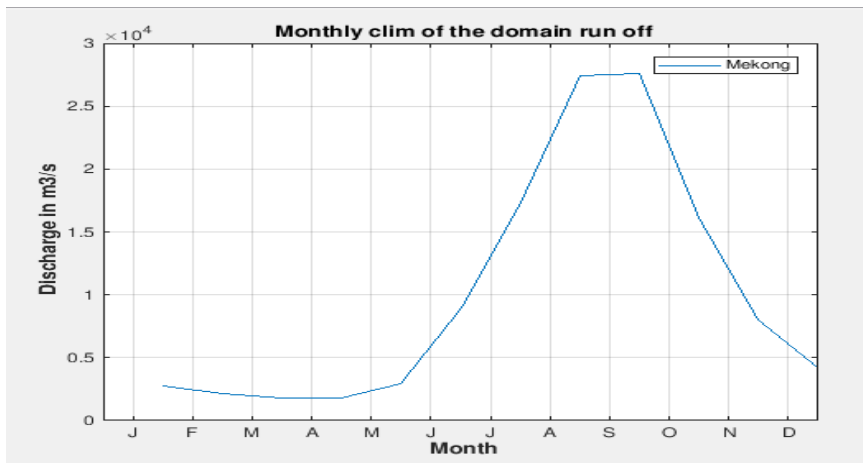

Fig. 17. Average flow of 12 months of the Mekong River



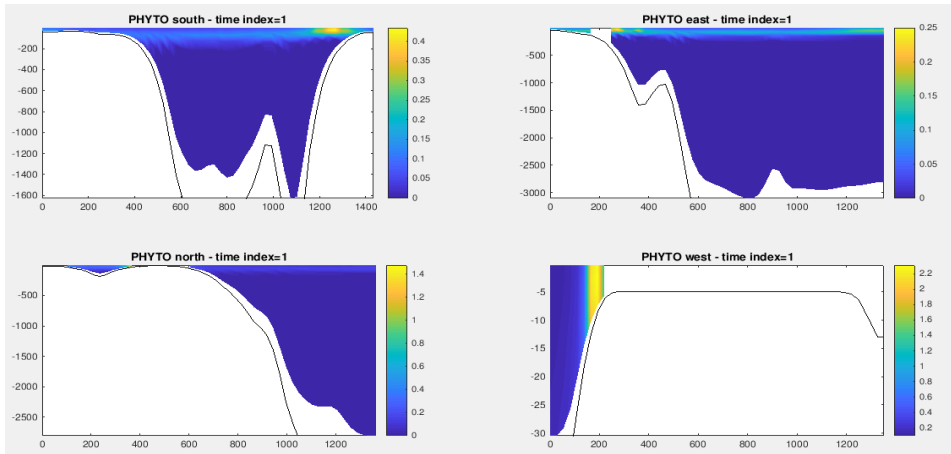

Fig. 18. Phytoplankton biomass boundary conditions

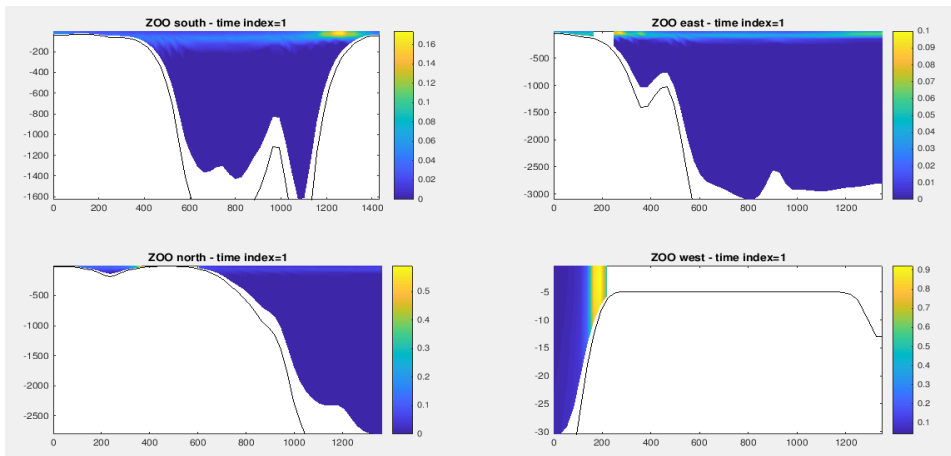

Fig. 19. Zooplankton biomass boundary conditions

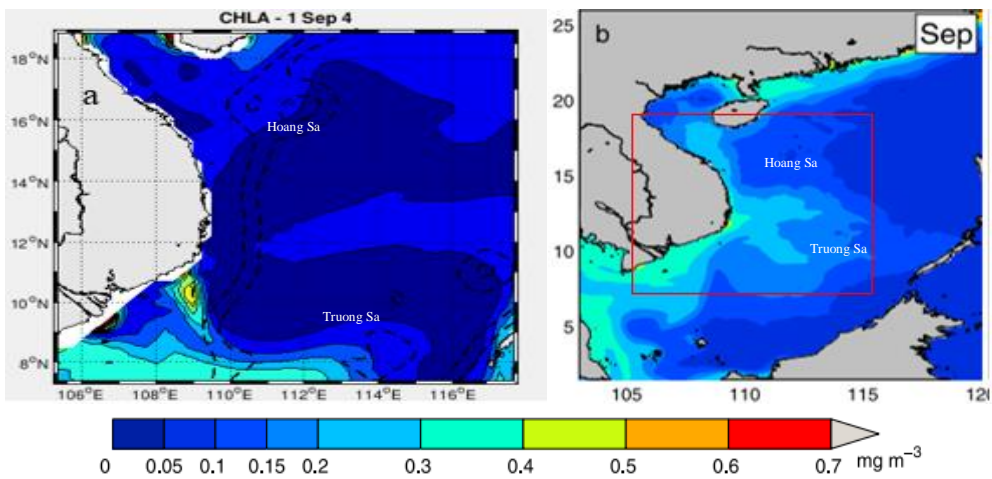

Fig. 20. Comparison of average chlorophyll concentration in September between: (a) this study's result and (b) Peng Xiu's result [10]

## RESULTS AND DISCUSSION

### Distribution of temperature and current fields

Some basic results of ROMS hydrodynamic model are shown in Figure 21, showing the usability of the model in simulating hydrodynamic processes.

In January (representing the Northeast wind season), the temperature of the surface layer in the study area ranges from 24°C to over 26.5°C and tends to increase from north to south. In the coastal area, especially in the northwest, the temperature only fluctuates in the range of 24–25°C related to the winter cold current system. In July, surface water temperature fluctuates

between 27.5°C and 29.5°C, forming a separate area that has the center temperature below 27°C due to summer upwelling activity. The area with the highest temperature during this period is the east one of the 110°E with the temperature of 29°C. The current system in 2 seasons with opposite directions accurately shows the basic and popular rules of the hydrodynamic field here. In particular, the appearance of local and small-scale vortices has been shown to be similar to previous studies [3]. This is the region with the strongest flow of the East Vietnam Sea circulation system during the seasons, with the maximum speed of 0.8 m/s, 0.4 m/s on average.

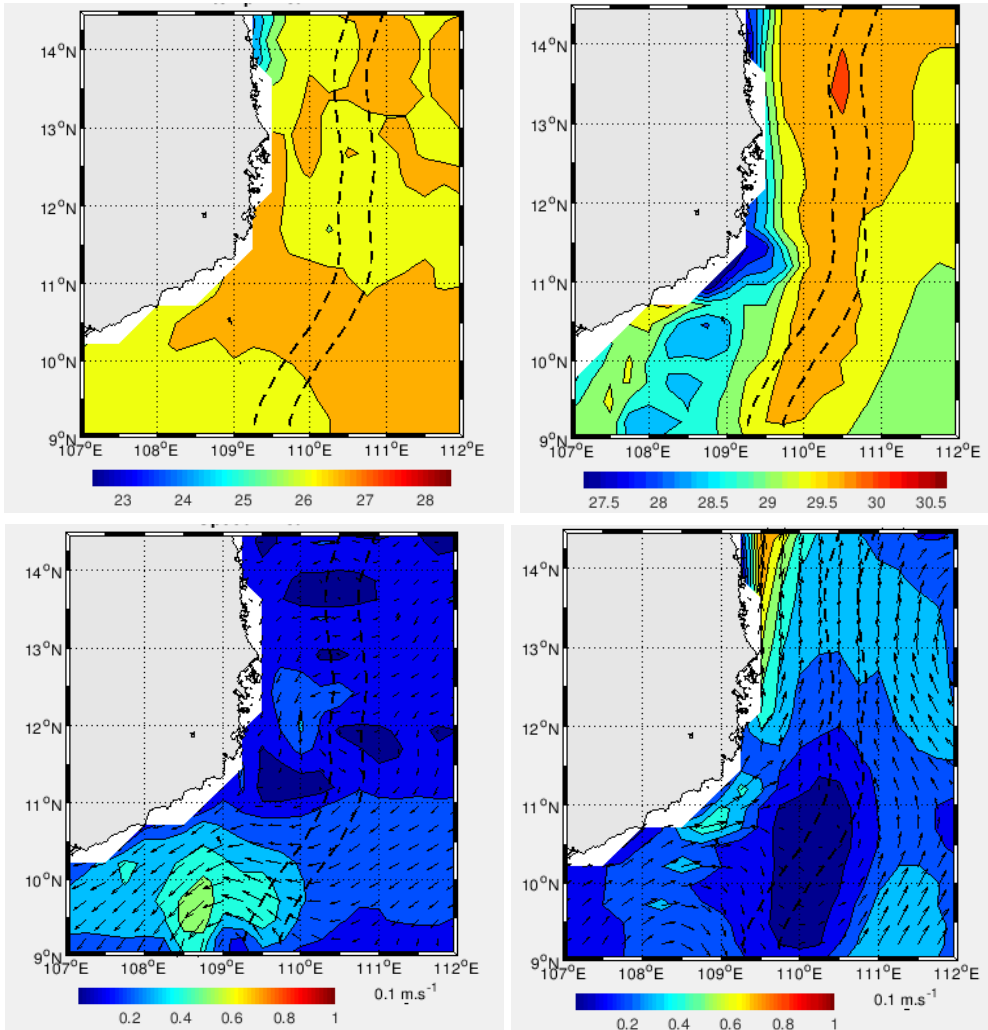

Fig. 21. Average temperature field (above) and velocity (below) of the sea surface layer in January (left) and July (right)

### Some marine ecological-environmental characteristics

The model results show that biomass of phytoplankton (P) in the studied surface layer in the northeast monsoon season ranges from less than 0.1 to above 0.4 mmol-N/m<sup>3</sup> (which are normal values encountered in this area [6, 7]), concentrated mainly in the eastern and southeastern areas of the sea, the largest reaches 0.5–0.6 mmol-N/m<sup>3</sup> near the 12°N latitude (fig. 22). In the southwest monsoon season, P strongly increases in the upwelling and stretches to the south with surface layer biomass above 1 mmol-N/m<sup>3</sup>, while the biomass in the eastern area is only 0.1–0.2 mmol-N/m<sup>3</sup>. This phenomenon is related to the ability of nutrient supplementation (N) of summer upwelling activity (see also fig. 24), as well as the eastern thermal background higher than 29°C (fig. 2) beyond the optimal value. The strong development of P in the summer upwelling area is reasonably qualitative, but the quantitative result (larger than the existing

research results [6, 7]) needs to be further studied, possibly due to defect of NPZD model as mentioned above as well as inappropriate selection of ecological parameters in the model.

In the vertical direction, (fig. 22) in a concerned cross section cutting through the summer upwelling area, there exists a maximum area of P biomass in the surface layer and near the surface. The maximum biomass decreases rapidly and reaches 0 at a depth of about 200 m due to untransmitted photosynthetic radiation. In the top 200m of water on the concerned cross section, the P biomass in January ranges from 0–0.045 mmol-N/m<sup>3</sup>, mainly growing in the surface layer to a depth of 120 m with the maximum area lying close to 50 m deep. In July, the most developed P biomass is in the 10–50 m water layer with biomass above 1.2 mmol-N/m<sup>3</sup> (fig. 22). This is also a common feature in tropical waters when the surface layer has abundant radiation exceeding the optimal value.

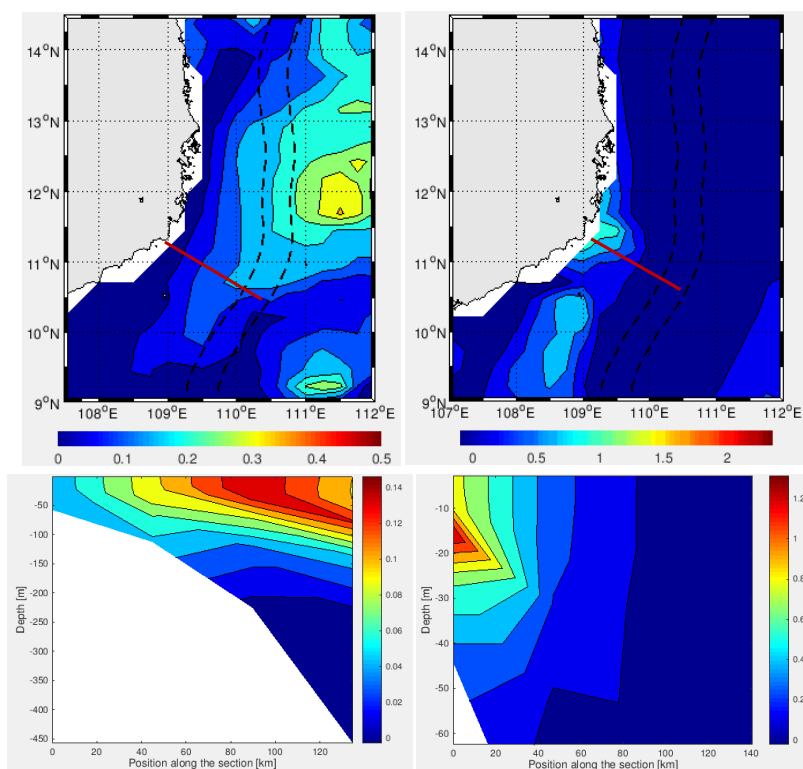

Fig. 22. Average phytoplankton biomass of the sea surface layer (above) and the concerned section (below) in January (left) and July (right)

For the heterotrophic plankton or zooplankton (Z), in January, Z biomass at the surface water is quite small, ranging from less than 0.01 to over 0.05 mmol-N/m<sup>3</sup>, concentrated mainly in the north of the interested area. The largest biomass of Z is in the vortex area (above 0.05 mmol-N/m<sup>3</sup>) and coincides with the development area of P (fig. 22). In July, Z also thrives in the upwelling area with biomass above 0.4 mmol-N/m<sup>3</sup>. Especially, in the southwest of the concerned area, the zooplankton has the maximum growth

of over 0.8 mmol-N/m<sup>3</sup> (greater than the previously studied values [6, 7]), while in the east of 110°E meridian it is significantly less developed. This is probably influenced by the flow of the Mekong River. In the vertical direction, at the interested cross-section cutting through the summer upwelling, there is also a maximum of the biomass of Z in the seasons similar to P (fig. 23). As mentioned above, the qualitative development of Z is reasonable, but the quantitative one also needs to be studied further.

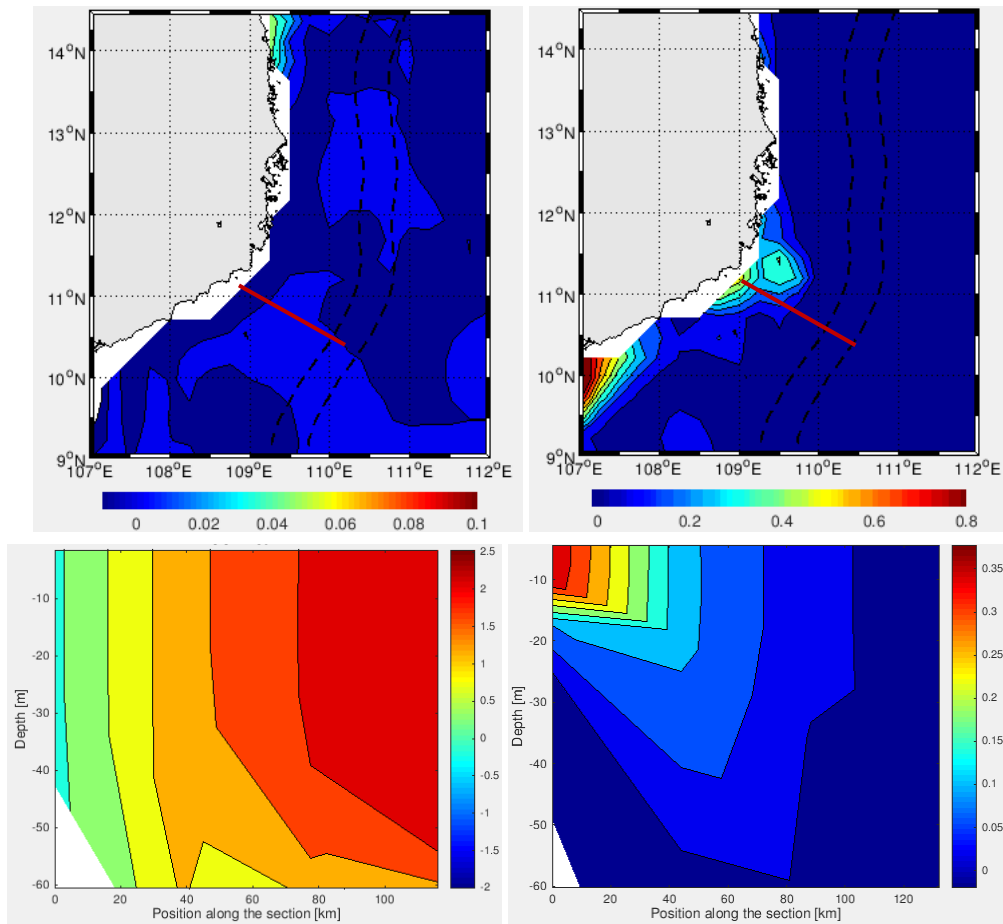

Fig. 23. Average zooplankton biomass of the sea surface layer (above) and the concerned section (below) in January (left) and July (right)

The above results have been tested qualitatively when compared with previous studies [6] (fig. 24), showing that the coupled ecological-hydrodynamic model in ROMS reflects the basic and popular rules of the

distribution and variation of ecological characteristics in the South Central Vietnam sea. However, quantitative values need to be further studied as mentioned.

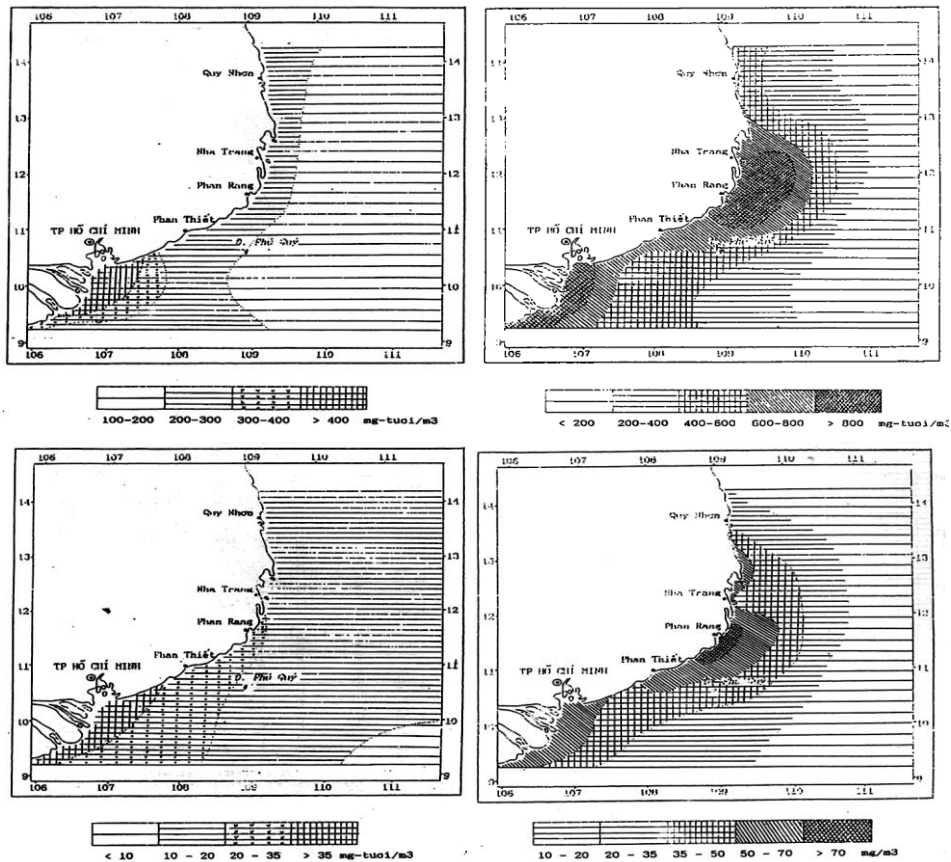

Fig. 24. Phytoplankton (above) and zooplankton (below) biomass distributions of the sea surface layer in January (left) and July (right) in the previous study [6]

## CONCLUSION

The results of applying the coupled ecological-physical dynamic models in ROMS in the South Central Vietnam sea show that in the northeast monsoon season, the marine plankton is distributed mainly in the northwest and the east of the concerned sea area, while in the southwest monsoon season they thrive in the upwelling area and surrounding water to the south. In these waters, the floating organism mainly grows in the top 200 meters of water, concentrated mainly in the 0–70 m layer and the maximum area is usually in the depth of 15–40 m below the surface. These results are not new but reasonable, in accordance with the natural law and previous studies, which are valuable to confirm the ability to apply the ecological-hydrodynamic model in the ROMS model for the region of South Central Vietnam sea.

The use of ecological coefficients is still difficult. By testing the model with many different coefficients, the best results were chosen as the research results in the paper. Besides, the source of input data as well as the data for verifying still does not have really good resolution, it needs to be better in the future.

With the results obtained from the research, it is possible to accept the reference value of applying the hydrodynamic-ecological combination model in the ROMS model, while confirming the research, development and application of ROMS in Vietnam. In the coming time, research on the combined model of hydrodynamics and ecology of ROMS for South Central Vietnam sea should continue to be carried out with better remediation of difficulties encountered while promoting

advantages which the coupled ROMS model obtained from this study.

**Acknowledgement:** The author who is a PhD student under the 911 project received funding for this research from the project. The author would like to thank this sponsor.

## REFERENCES

- [1] Haidvogel, D. B., Arango, H., Budgell, W. P., Cornuelle, B. D., Curchitser, E., Di Lorenzo, E.,... and Levin, J., 2008. Ocean forecasting in terrain-following coordinates: Formulation and skill assessment of the Regional Ocean Modeling System. *Journal of Computational Physics*, 227(7), 3595–3624.
- [2] Penven, P., Cambon, G., Tan, T., Marchesiello, P., and Debreu, L., 2010. ROMS AGRIF/ROMSTOOLS user's guide. *Institut de Recherche pour le Developpement, Dunkerque*.
- [3] Nguyen Minh Huan, Pham Van Sy, Duong Hong Son, 2010, The process of testing the forecast of the current, the salinity, the temperature and the total water level for the East Vietnam Sea area by ROMS model. *VNU Journal of Science: Natural Sciences and Technology*, 26(3S), 362.
- [4] Gildas Cambon, Isabelle Dadou, 2013. Physical-Biogeochemical modeling - Practical ROMS\_AGRIF using the NPZD model. *The lectures at University of Science and Technology of Hanoi, Vietnam*.
- [5] Doan Bo, 2005. A model for nitrogen transformation cycle in marine ecosystem. *Proceedings Extended Abstracts Volume, Theme 1, Session 3: Biogeo-chemical Cycling and Its Impact on Global Climate Change, 6<sup>th</sup> IOC/WESTPAC International Scientific Symposium, 19–23 April 2004, Hangzhou, China, Published by Marine and Atmospheric Lab, School of Environmental Earth Science, Hokkaido University, 54, Japan*.
- [6] Doan Bo, 1997. Mathematical model of distribution of floating organisms and primary biological productivity in the waters of upwelling continental shelf in South Central Vietnam sea. *Journal of Biology*, 19(4), 33.
- [7] Doan Bo, 2006. About a marine ecosystem model and some results of application to open areas of centre Vietnam. *VNU Journal of Science*, 22(1AP), 27.
- [8] Fasham, M. J. R., Ducklow, H. W., and McKelvie, S. M., 1990. A nitrogen-based model of plankton dynamics in the oceanic mixed layer. *Journal of Marine Research*, 48(3), 591–639.
- [9] Website: <https://www.croco-ocean.org/>
- [10] Xiu, P., and Chai, F., 2011. Modeled biogeochemical responses to mesoscale eddies in the South China Sea. *Journal of Geophysical Research: Oceans*, 116(C10). doi:10.1029/2010JC006800.